

KKGD-B SERIES

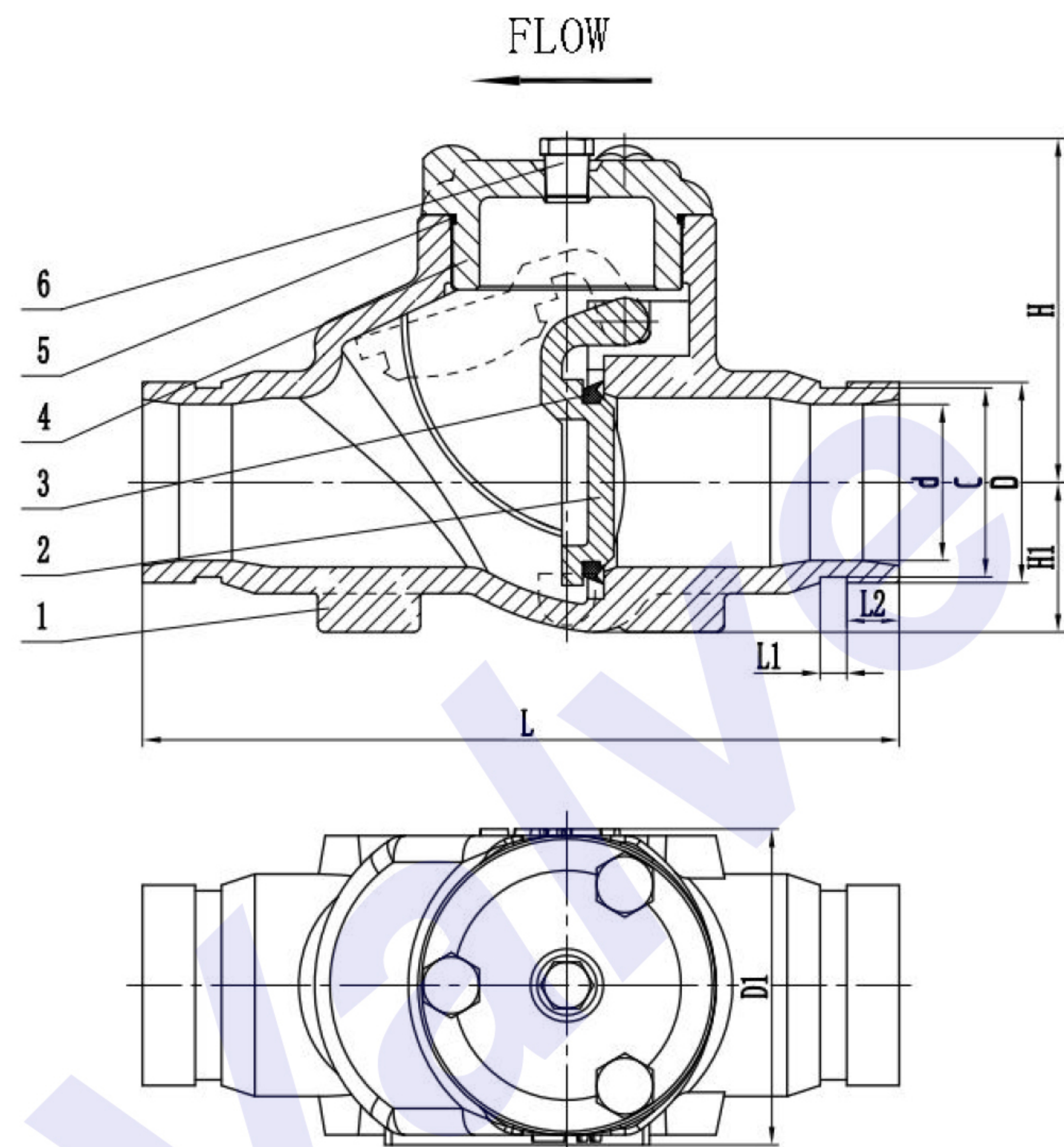

Product description

The Oil Field Check Valve is an ideal choice for oil & gas production lines where back flow is a concern. The swing check offers simplicity and is easily repairable with top entry to the valve internals. The function of the check valve is to prevent the backflow of medium in the pipeline. The check valve is an automatic valve, and the opening and closing parts open or close automatically by the force of the flowing medium. The check valve is only used on the pipeline with one-way flow of medium to prevent the backflow of medium and prevent accidents. Applicable medium: water, oil, steam, acid medium, etc.

Technical parameter

- » FULL PORT
- » 300, 600, 750, 1000 W.O.G
- » THREADED VALVE COVER
- » CF8 DISK, VITON SEAL
- » GROOVED DIMENSIONS CONFORM TO ANSI/AWWA C606
- » Test API598

KKGD-B SERIES

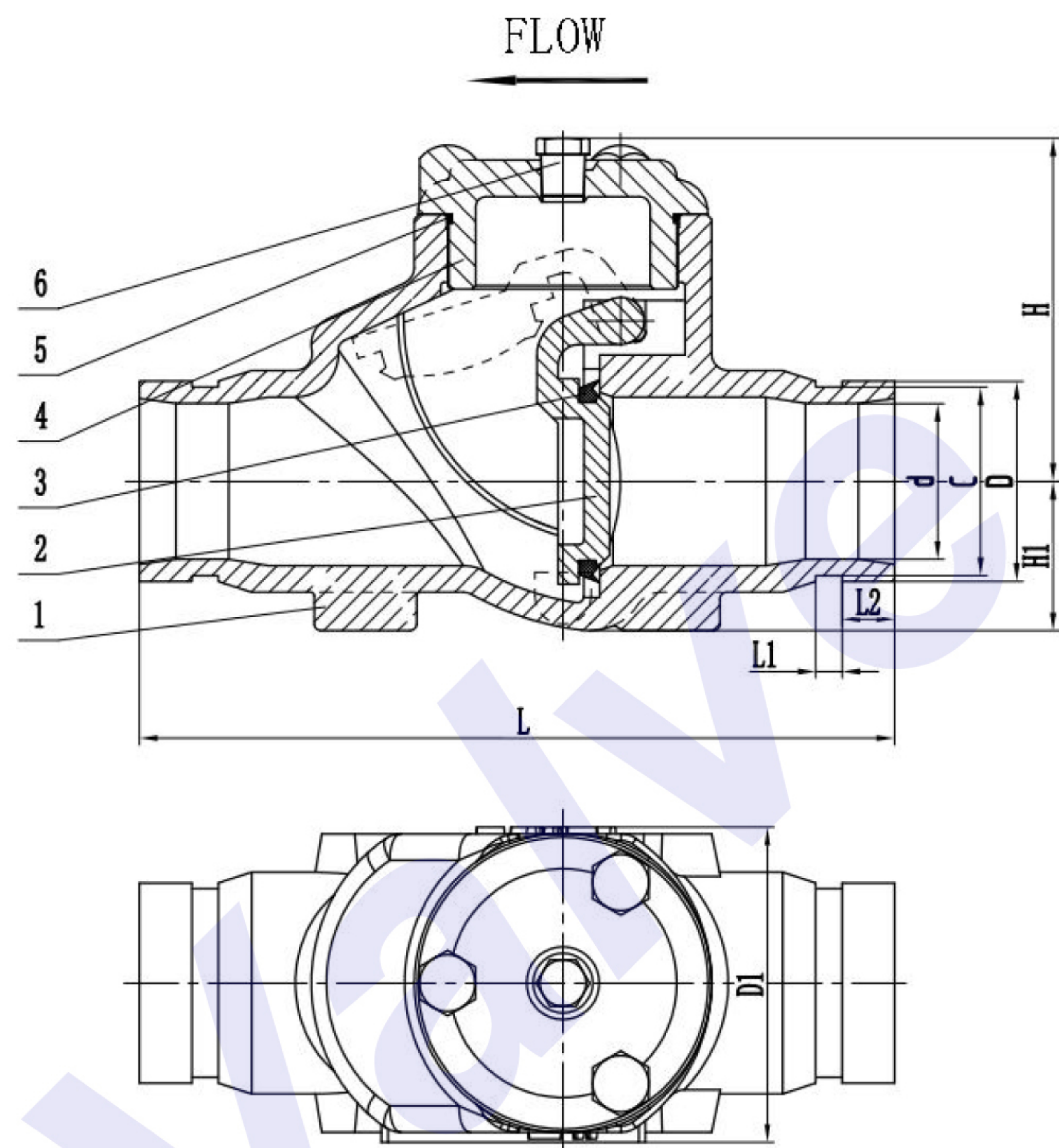

Main parts and materials

No.	Part name	Material
1	BODY	ASTM A395 DI
2	DISK	ASTM A351 CF8
3	O-RING SEAL	VITON
4	BONNET	ASTM A395 DI
5	GASKET	VITON
6	BONNET SCREW	ASTM A105

Main dimensions (in)

Size	L	D	C	d	L1	L2	H	H1	D1	Weight(lbs)
2	9.00	2.375	2.250	1.85	0.31	0.63	4.09	1.77	3.74	12.1